

NO.	REVISION	DATE
1	REMOVE RIB AROUND PARTING LINE.	10/22/07
2	REPLACE ALUMINUM FILL WITH MOLDED FILL.	4/21/08
3	REPLACE PRIME W/ ROCHESTER	9/10/09
4	ADD 3/8 NPT INSERT W/ PLUG	4/24/10

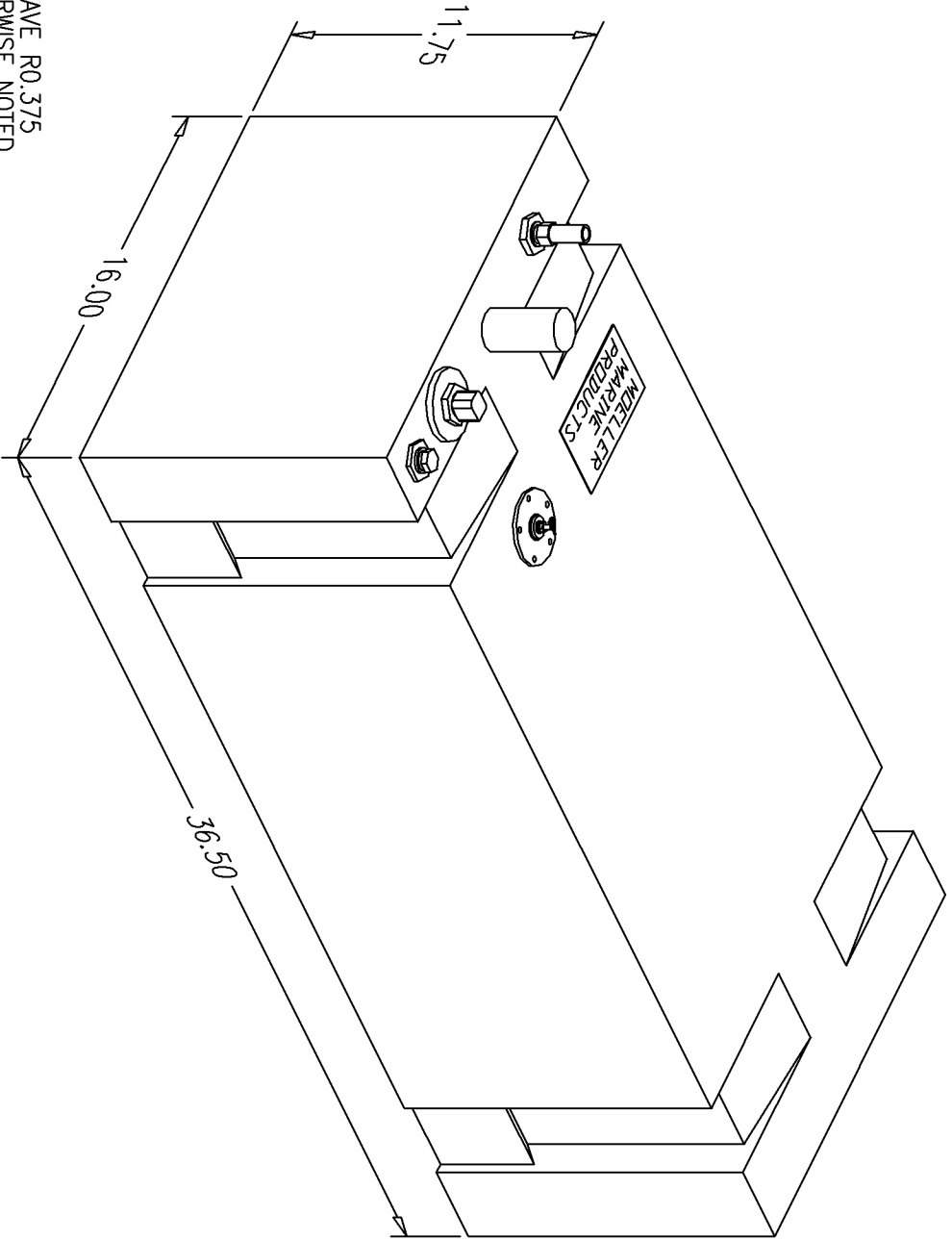

NOTE: ALL EDGES HAVE R0.375
UNLESS OTHERWISE NOTED

PAGE 1 OF 3
© 2007 MOELLER MARINE PRODUCTS
ALL RIGHT RESERVED

THIS DRAWING AND THE ATTACHED DRAWINGS (AND THE DATA SHOWN THEREON) IS CONFIDENTIAL AND PROPRIETARY AND SHALL NOT BE USED, DISCLOSED TO OTHERS, REPRODUCED FOR ANY PURPOSE EXCEPT FOR QUOTATION TO OR ORDER BY MOELLER MARINE PRODUCTS, INC. AND/OR ITS SUBSIDIARIES WITHOUT THEIR WRITTEN CONSENT TO THE USE OF SUCH DRAWINGS AND/OR DATA.

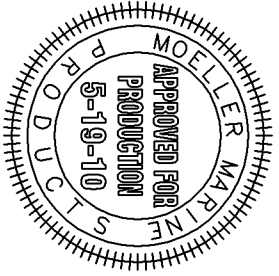

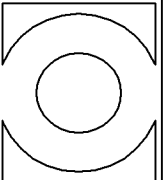
		DESCRIPTION	27 GALLON FUEL TANK (032527)	
		PART #	FT2799-1	COLOR NATURAL
		MATERIAL	CROSSLINK POLYETHYLENE	
		TOLERANCES	±1.5% UNLESS OTHERWISE NOTED	
		WALL THK.	0.200"	DATE 4/24/10
		DRAWN BY	MOELLER ENGINEERING	

