

GENERAL NOTES:

1. USE .027 IN./IN. SHRINK ALLOWANCE
2. MOLD TO BE FULLY WELDED INSIDE AND STITCH WELDED OUTSIDE
3. CLAMPING TO BE WITH 1/2" X 1-1/2" GRADE 8 BOLTS, GRADE 5 NUTS AND NUT HOLDERS.
4. LID RING RECESS TO HAVE KNIFE EDGE ON INSERT TO MINIMIZE TRIMMING.

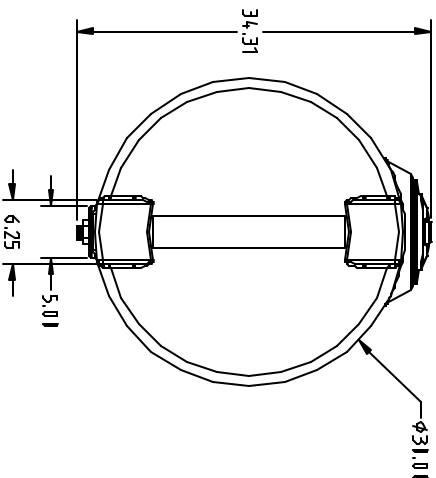
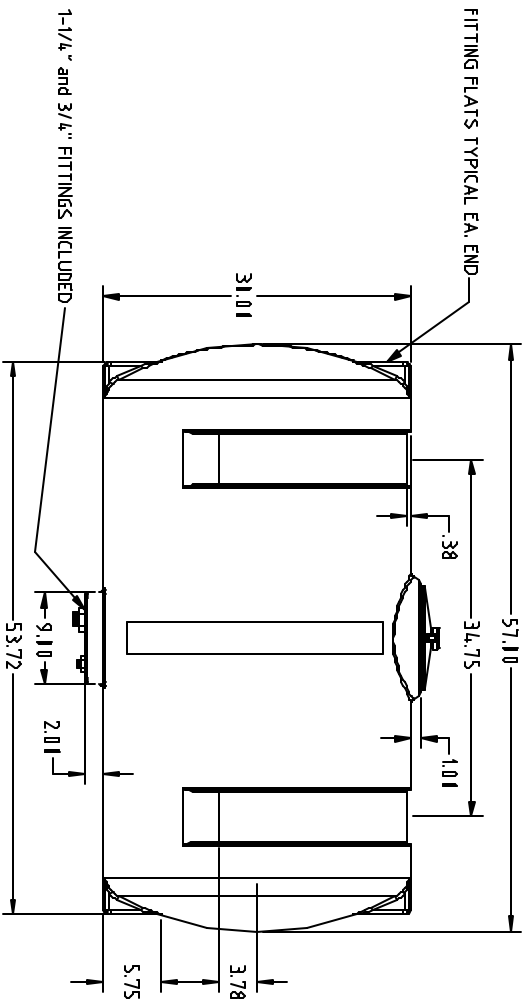
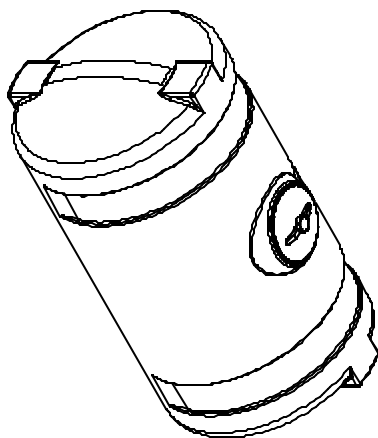
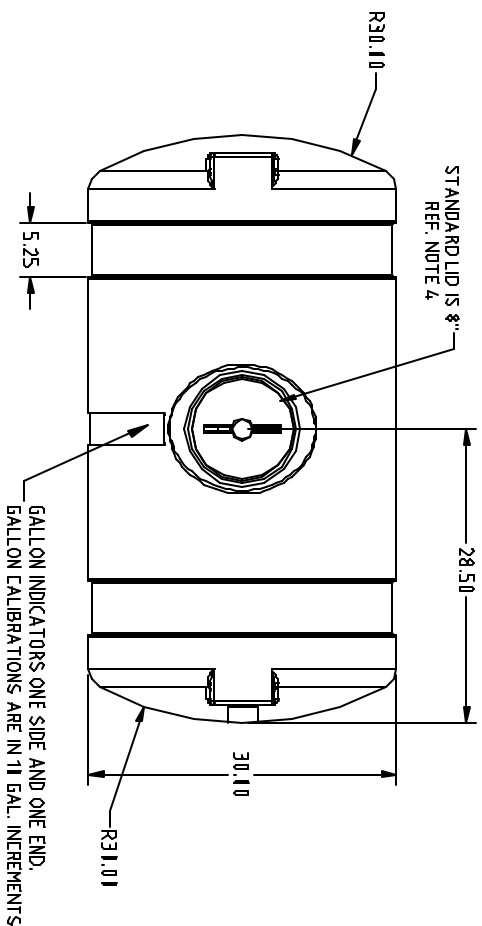

REV	DESCRIPTION	DATE	APPRD

DRAWN / DATE		APPRD. / DATE	
	REH/9/14/01		REH/9/14/01

MATERIAL / SHOT WEIGHT			
M111	M134	U625	P938
	48		



 A DIVISION OF DEK HARTOG INDUSTRIEALING

CLIENT / DESCRIPTION: ACE 150 GALLON HORIZONTAL TANK (30" DIA.)

ALL DIMENSIONS ARE IN DECIMAL INCHES
 TOLERANCES UNLESS OTHERWISE SPECIFIED
 + .5% @ 68° F

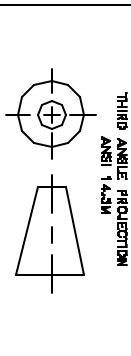

NOTES:
1. 210 NOMINAL WALL

SCALE: N.S.
 PART NO.: HZ0150-30

HZ0150-30