

4

3

2

1

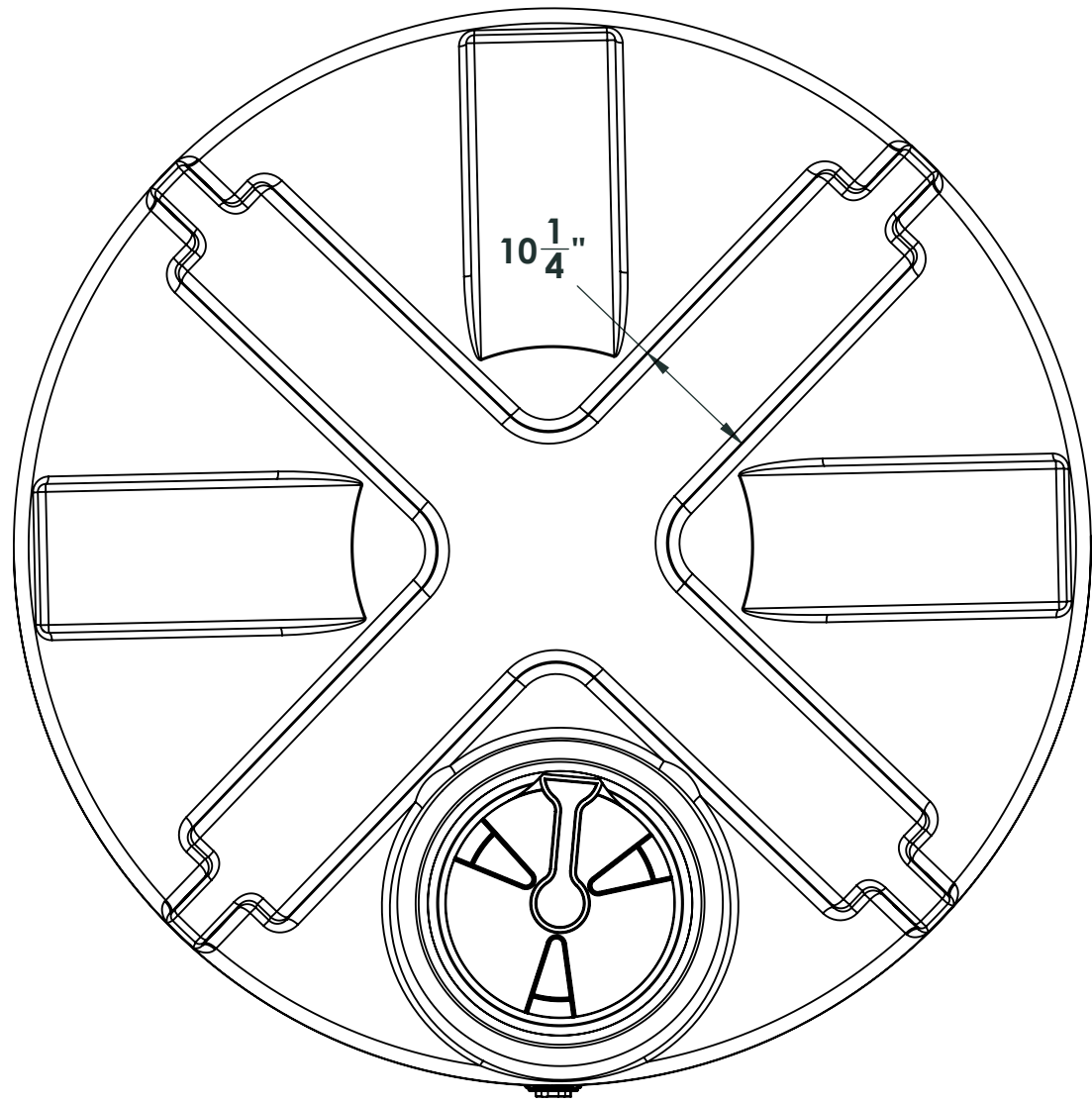

16 inch lid

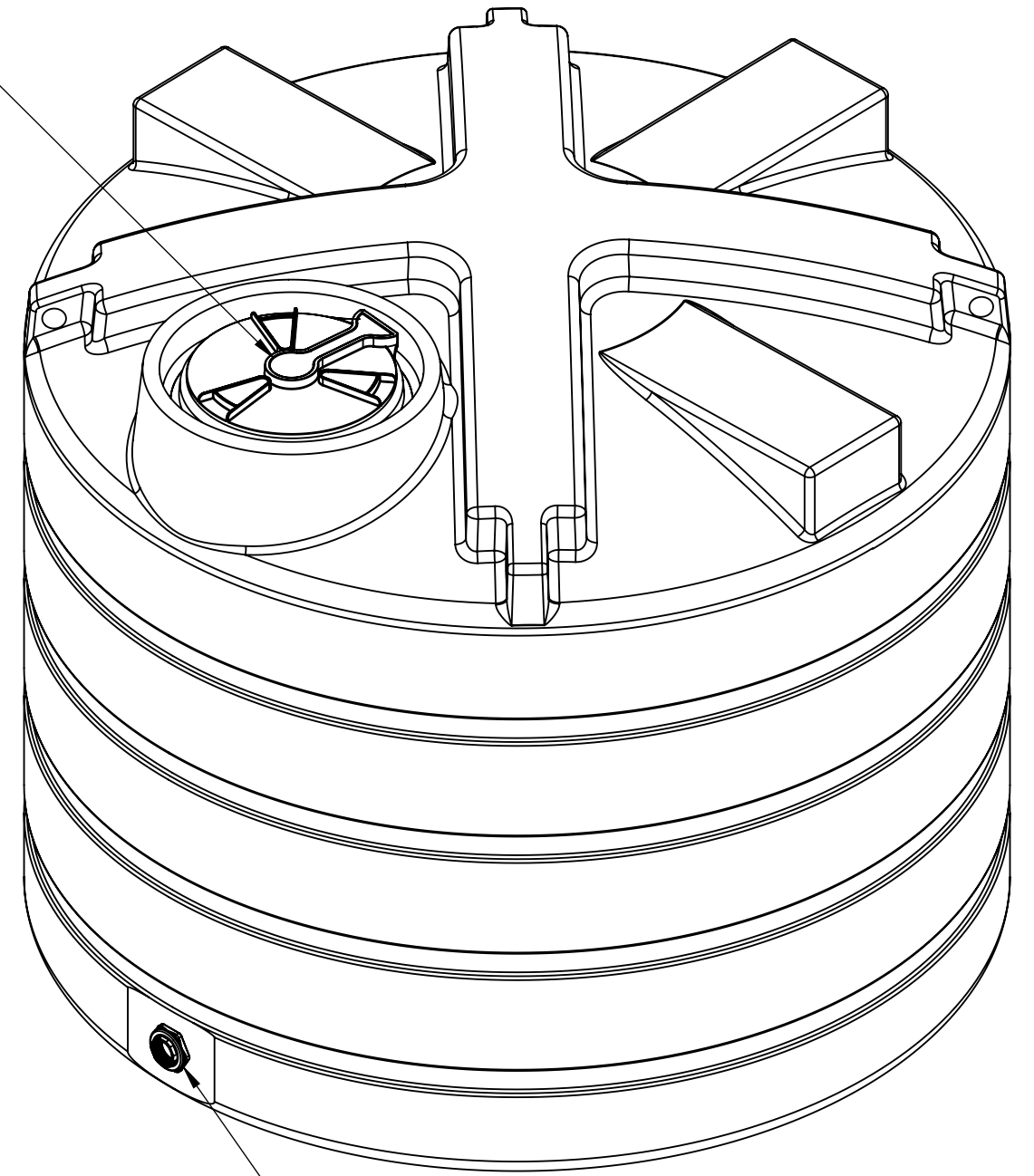

2 inch threaded fitting

D

D

C

C

B

B

A

A

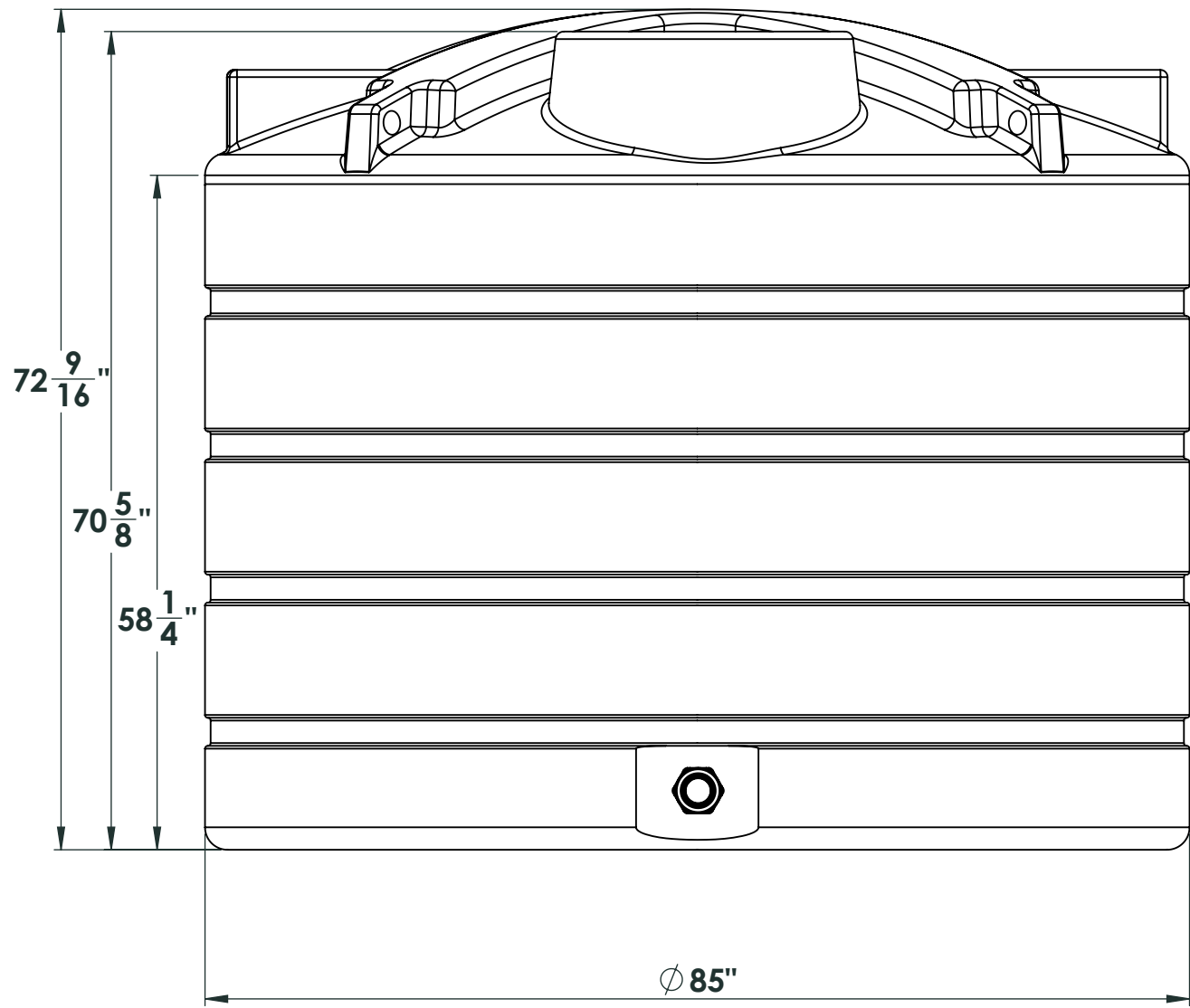

10 1/2"

6 5/8"

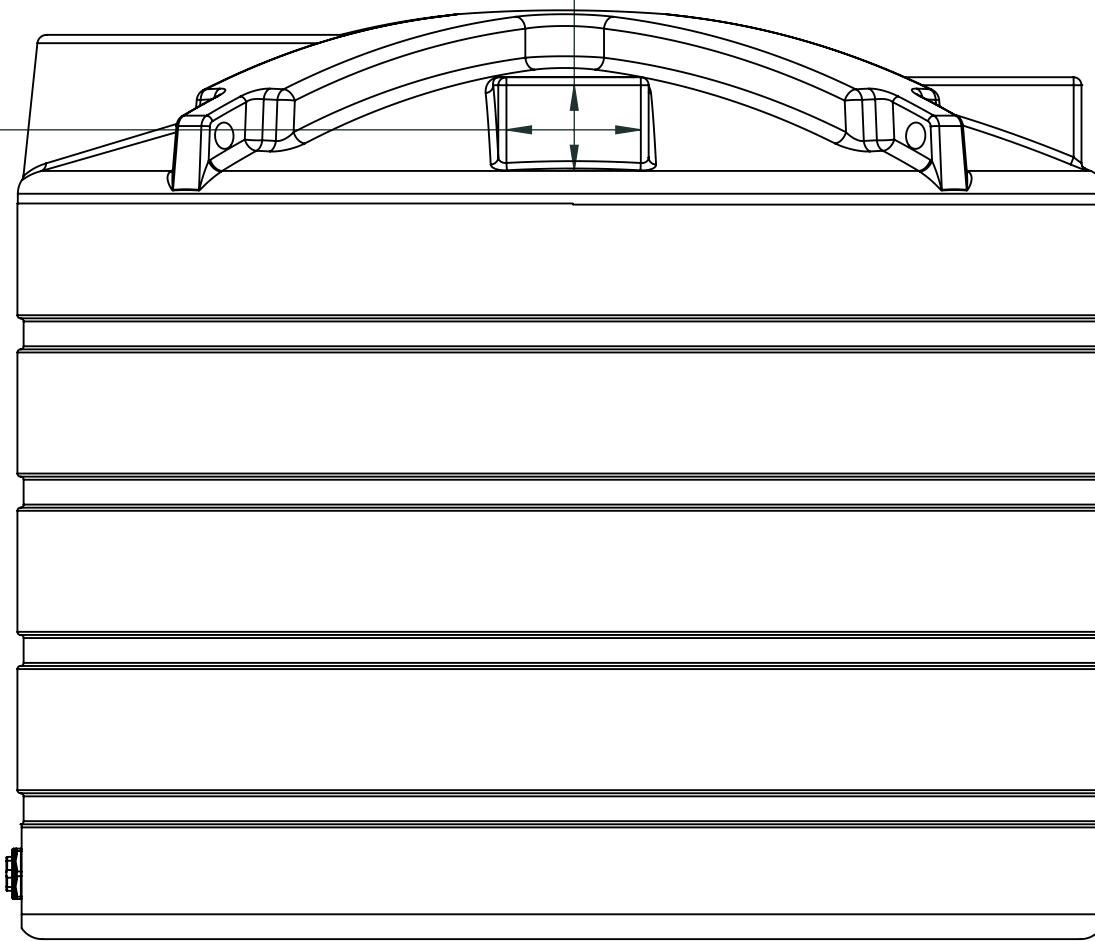

NOTE: Allow +/- 1.5% Shrinkage

PROPRIETARY AND CONFIDENTIAL
 THE INFORMATION CONTAINED IN THIS DRAWING IS THE SOLE PROPERTY OF ENDURAPLAS LLC. ANY REPRODUCTION IN PART OR AS A WHOLE WITHOUT THE WRITTEN PERMISSION OF ENDURAPLAS LLC IS PROHIBITED.

UNLESS OTHERWISE SPECIFIED:		NAME	DATE	ENDURAPLAS LLC	
DIMENSIONS ARE IN INCHES		DRAWN	DNS	10/31/16	TITLE:
TOLERANCES:		CHECKED			THV01350
FRACTIONAL ±		ENG APPR.			SIZE DWG. NO.
ANGULAR: MACH ± BEND ±		MFG APPR.			REV
TWO PLACE DECIMAL ±		Q.A.			1
THREE PLACE DECIMAL ±		COMMENTS:			SCALE: 1:50 WEIGHT:
INTERPRET GEOMETRIC TOLERANCING PER:					SHEET 1 OF 1
MATERIAL					
FINISH					
NEXT ASSY	USED ON				
APPLICATION					
DO NOT SCALE DRAWING					

4

3

2

1