

For use with:

 **MicroFAST[®] Flex 0.4**

 **MicroFAST[®] Flex 0.5**



CONTENTS

GENERAL INFORMATION	1
ABOUT FAST®	1
GENERAL NOTES	2
MAJOR COMPONENTS	3
EXPLODED VIEW OF UNIT	4
LAYOUT	5
LOCATION	6
NON-SUPPLIED TOOLS AND MATERIALS	6
DETAILS OF FAST® SUB-ASSEMBLY.....	7
MODULE INSTALLATION.....	7
INSTALLATION THROUGH TANK RISER	7
ASSEMBLY INSIDE OF THE TANK.....	8
COMPONENT INSTALLATION.....	8
SECURING BLOWER AIR SUPPLY LINE	8
VENTING	10
BLOWER INSTALLATION.....	10
BLOWER WIRING DIAGRAMS	11
BLOWER WIRING DIAGRAMS	12
CONTROL PANEL INSTALLATION.....	12
CONTROL PANEL DETAILS.....	13
SMALL CONTROL PANEL	14
SMALL PANEL SCHEMATICS.....	16
FINAL INSPECTION AND STARTUP	17
LIMITED WARRANTY	18
TERMS AND CONDITIONS	18
KEEP FOR YOUR RECORDS	19

GENERAL INFORMATION

Thank you for purchasing a BioMicrobics FAST® system. One or more of the following patents protects this process: 3,966,599; 3,966,608; 3,972,965; 5,156,742. The MicroFAST® Flex 0.4, Flex 0.5, 0.5, 0.625, 0.75, 0.9 and 1.5 systems meet NSF/ANSI Standard 40, Class 1 and Standard 245 certifications for wastewater treatment devices. If you have questions regarding any BioMicrobics products, please contact us:

1-800-753-FAST (3278) or +1-913-422-0707

e-mail: onsite@biomicrobics.com

ABOUT FAST®

The FAST® (Fixed Activated Sludge Treatment) system uses naturally occurring bacteria (biomass) to treat sewage for dispersal into the environment. This continuous process provides the biomass with food (waste) and air in a suitable environment. Dead bacteria and non-biodegradable waste settle and accumulate in the bottom of the tank for periodic removal.

The FAST® assembly consists of two components: the treatment module and blower. The blower provides air to the system via the air supply pipe. The air supply pipe and draft tube create an airlift, which mixes oxygen and waste throughout the media inside the tank. Bacteria, supported by the air from the airlift, grows on the media and digests the waste. Finally, a vent pipe expels vapors created by the process.



ALWAYS SECURE ALL ACCESS COVERS TO PREVENT UNAUTHORIZED PEOPLE FROM ENTERING THE TANK. ONLY QUALIFIED SERVICE PERSONNEL SHOULD OPEN ACCESS PORTS AND COVERS.

INFECTIOUS ORGANISMS ALSO EXIST IN A SEPTIC TANK, SO IF ANY CONTACT WITH WASTEWATER OCCURS, IMMEDIATELY WASH AND DISINFECT ALL EXPOSED AREAS AND CONTACT PERSONAL PHYSICIAN. FAILURE TO DO SO COULD RESULT IN SEVERE SICKNESS OR DEATH.

DO NOT USE AN OPEN FLAME OR CAUSE A SPARK NEAR A SEPTIC TANK'S ACCESS POINTS. GASES EMANATING FROM SEPTIC TANKS CAN EXPLODE IF IGNITED OR BE DEADLY IF INHALED.

1. GENERAL

The treatment system is complete with all needed equipment as shown on the drawings and specified therein. The following equipment is provided by BioMicrobics, Inc. with purchase of the system: (a) the FAST® system sub-assembly, (b) the blower assembly, and (c) blower controls and alarms. All other items needed for installation and operation are not included.

The contractor will install the FAST® treatment system as manufactured by BioMicrobics, Inc. The contractor will ensure the proper fabrication of the tank, coordinate between the tank suppliers and FAST® system suppliers, arrange delivery to the job site, and oversee the installation of the FAST® unit. The tank must provide adequate pump-out access and must conform to local, state, and all other applicable codes. The tank must also be level within $\pm 1/2$ in [12 mm].

2. MEDIA

The FAST® media is made of rigid PVC, polyethylene, or polypropylene, and it is supported by the polyethylene insert. The media will be fixed in position and contain no moving or wearing parts, and it will not corrode. The media has been designed, and will be installed, to ensure that sloughed solids descend through the media to the bottom of the septic tank for easy cleanout.

3. REMOTE MOUNTED BLOWER

The blower must be set in a dry, stable place, and its elevation must be higher than the normal flood level. A two-piece, rectangular housing is included with the unit. The discharge airline from the blower to the FAST® system is not included and must be provided and installed by the contractor.

4. ELECTRICAL

The electrical source should be within 150 ft [45 m] of the blower; consult local codes for longer wiring distances. Wiring distances must prevent significant voltage loss. All wiring must conform to all applicable codes (IEC, NEC, etc.). All conduit and wiring must be supplied by the contractor.

5. CONTROLS

The control panel, which provides power to the blower, comes with an alarm system consisting of a visual and audible alarm that will indicate blower circuit failure and high motor load. The control panel is equipped with an SFR® (Sequencing Fixed Reactor) timed control feature. A manual silence button is included.

6. INSTALLATION AND OPERATING INSTRUCTIONS

Written instructions for proper installation, use, and service of the FAST® system (manuals) are included with the product and are available online at the BioMicrobics website. Installation of the FAST® system must be carried out in accordance with the written instructions provided in the Installation Manual. Moreover, all work related to the installation must be done in accordance with local codes and regulations.

MAJOR COMPONENTS

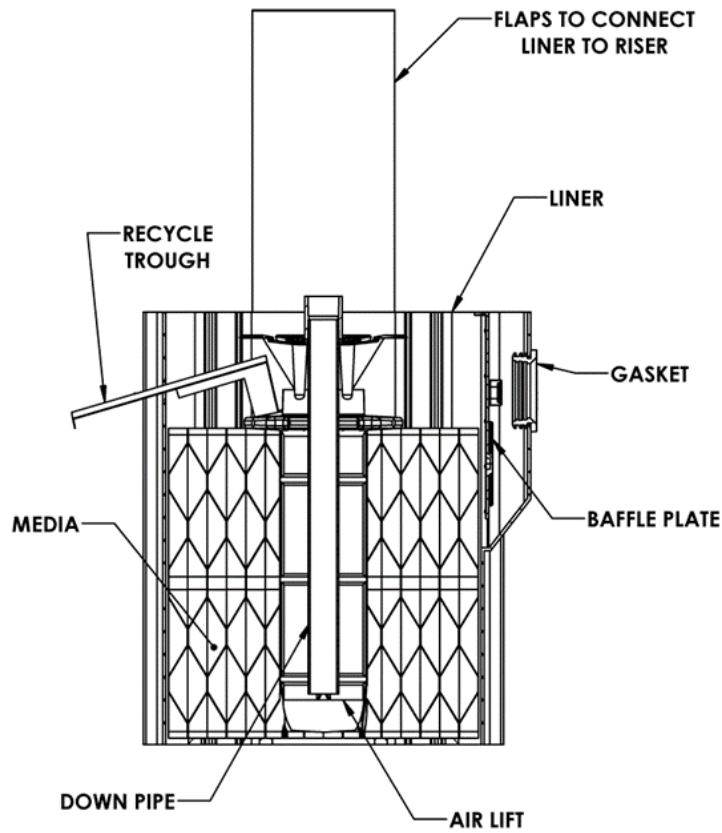
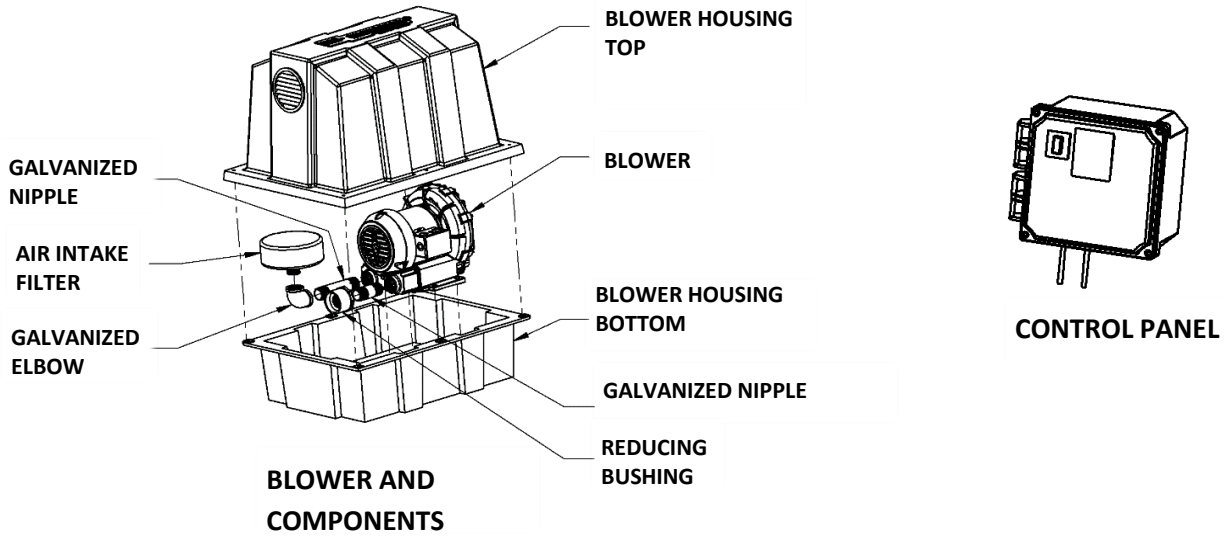

Images may differ in appearance from the actual product.

EXPLODED VIEW OF UNIT

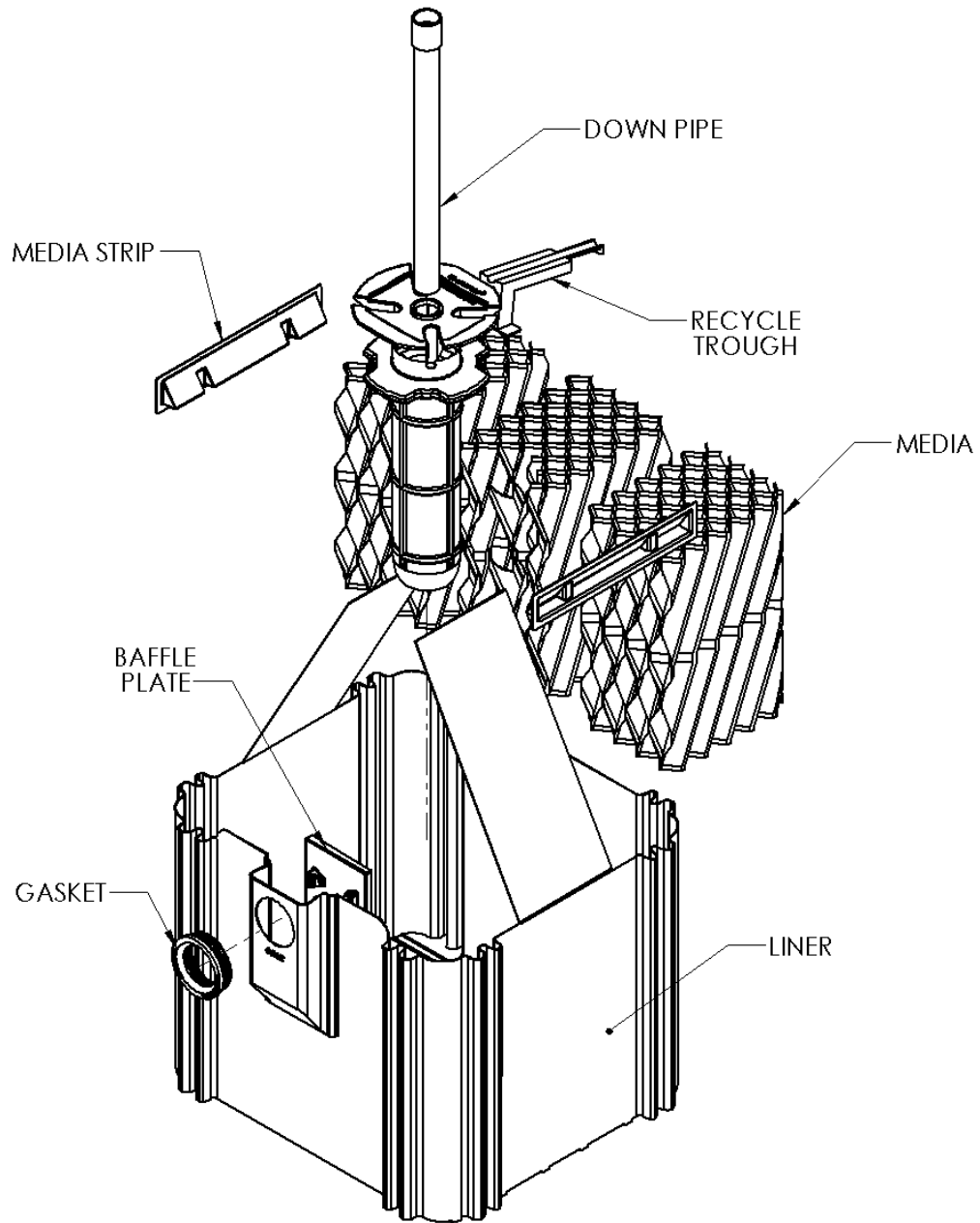

MicroFAST Flex 0.5
SOME ITEMS NOT SHOWN FOR CLARITY
MEDIA STRIPS ARE FOR FLEX 0.5 ONLY

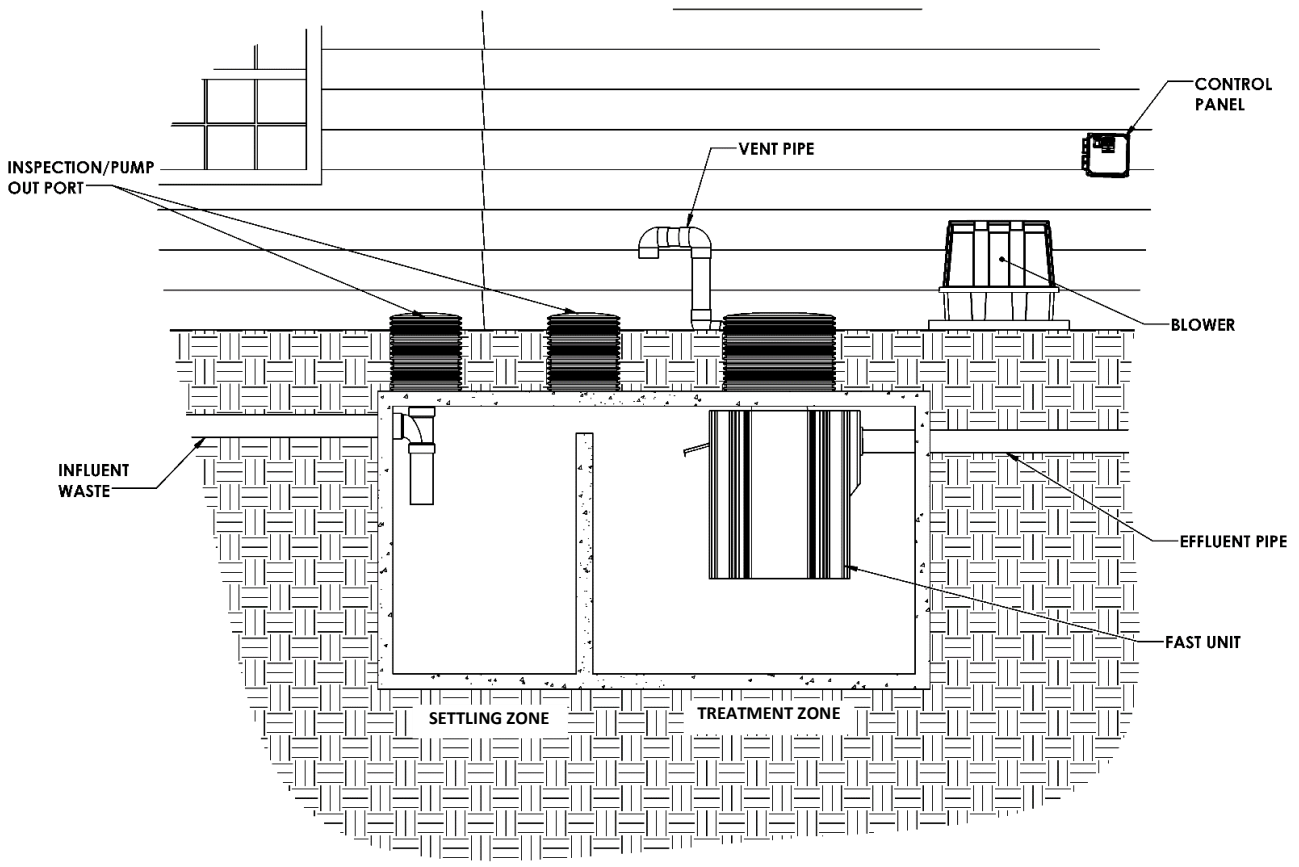

TYPICAL LAYOUT OF MICROFAST FLEX 0.4 AND MICROFAST FLEX 0.5



Always have all utility lines and equipment marked by a locating service prior to performing any work. Failure to do so could result in severe bodily injury or death.

FAST® systems may be located in the same position relative to the house and water supply as any conventional septic system. However, some basic guidelines should be followed:

1. The FAST® system must be located so that sufficient slope ($\geq 2\%$, $\frac{1}{4}$ in/ft) is provided for the influent and effluent lines.
2. Excessive back pressure must not be applied to the blower. Follow all installation guidelines.
3. The method and arrangement for effluent discharge must not interfere with the treatment plant's operation.



Persons coming in contact with wastewater must immediately wash all exposed areas with disinfecting cleaner and contact their personal physician. Failure to do so could result in severe sickness or death.



Hazards exist in confined spaces such as a septic tank. All confined space precautions must be followed if entering a tank. Always keep tank openings covered during storage and installation.

NON-SUPPLIED TOOLS AND MATERIALS

NOTE: Other tools may be required to complete installation

- | | |
|----------------------------------------------------------------------------------------------------------------------------------------------------------------------------------------------------------------------------------------------------------------------------------|-----------------------------------------------------------------------------------------------------------------------------------------------------------------------------------------------------------------------------------------------------------|
| <ol style="list-style-type: none"> 1. Septic tank that meets all applicable requirements and standards 2. Safe lifting mechanism to move the FAST® unit 3. Piping for observation/vent port, air lines, and vent lines 4. PVC pipe saw | <ol style="list-style-type: none"> 5. Pipe lubricant/soap 6. PVC primer and glue 7. Base for blower assembly 8. Mounting screws for control panel 9. Electrical conduit, fittings, and specified wires |
|----------------------------------------------------------------------------------------------------------------------------------------------------------------------------------------------------------------------------------------------------------------------------------|-----------------------------------------------------------------------------------------------------------------------------------------------------------------------------------------------------------------------------------------------------------|

DETAILS OF FAST® SUB-ASSEMBLY

FAST® Model	Unit Dimension	SUB-ASSEMBLY
	W X H X L	WEIGHT
Flex 0.4	30 X 34 X 38 in	37 lbs.
	[77 X 86 X 97 cm]	[17 kg]

FAST® Model	Unit Dimension	SUB-ASSEMBLY
	W X H X L	WEIGHT
Flex 0.5	35 X 32 X 39 in	39 lbs.
	[89 X 81 X 99 cm]	[18 kg]

MODULE INSTALLATION

INSTALLATION THROUGH TANK RISER

1. Remove the airlift and recycle trough from the center of the media blocks. **(For the Flex 0.5 only)** remove the two screws holding the media strip in place and remove. Remove each media block and set aside.
2. Use a ratchet strap or bungee cord to fold and compress the flexible FAST liner so that it will fit inside of a 20 inch [51 cm] diameter.
3. Insert the FAST® liner into the tank riser at the treatment compartment end with the liner gasket facing the outlet.
4. Remove the strap for folding the liner and allow it to expand inside of the tank.
5. Raise the liner using the mounting flaps so that the outlet of the tank is level with the liner gasket.
6. Secure the mounting flaps to the side of the riser using at least two fasteners per flap and spaced evenly apart.
7. Insert the outlet pipe through the tank boot and firmly into the FAST liner outlet gasket.



ASSEMBLY INSIDE OF THE TANK

1. Re-assemble the FAST components inside of the tank starting with the media blocks. Put the media blocks in the corners first, then the blocks with the hole cut for the airlift. **(For the Flex 0.5 only)** Re-assemble media strips to secure the media blocks.
2. Insert the airlift into the center of the media and bend the recycle trough so that it goes through the hole at the back of the liner.



COMPONENT INSTALLATION

SECURING BLOWER AIR SUPPLY LINE

Insert cut length of 2" (51 mm) PVC air supply pipe through the airline gasket in unit lid. Use the 6" hole in the lid for access to connect and glue air supply to airlift coupling. Plumb the airline to the blower location using required piping. Be sure airline is properly backfilled when installed. Airline piping to FAST® unit should not exceed 100 ft [30.5 m] with no more than 4 elbows. All connections must be air/watertight. The air supply line inside the tank must be secured with non-corrosive clamps every 2 ft to prevent breaking.

***Installation Tip: Recommended incorporating a PVC union into the piping assembly to facilitate maintenance and future disassembly as shown below.

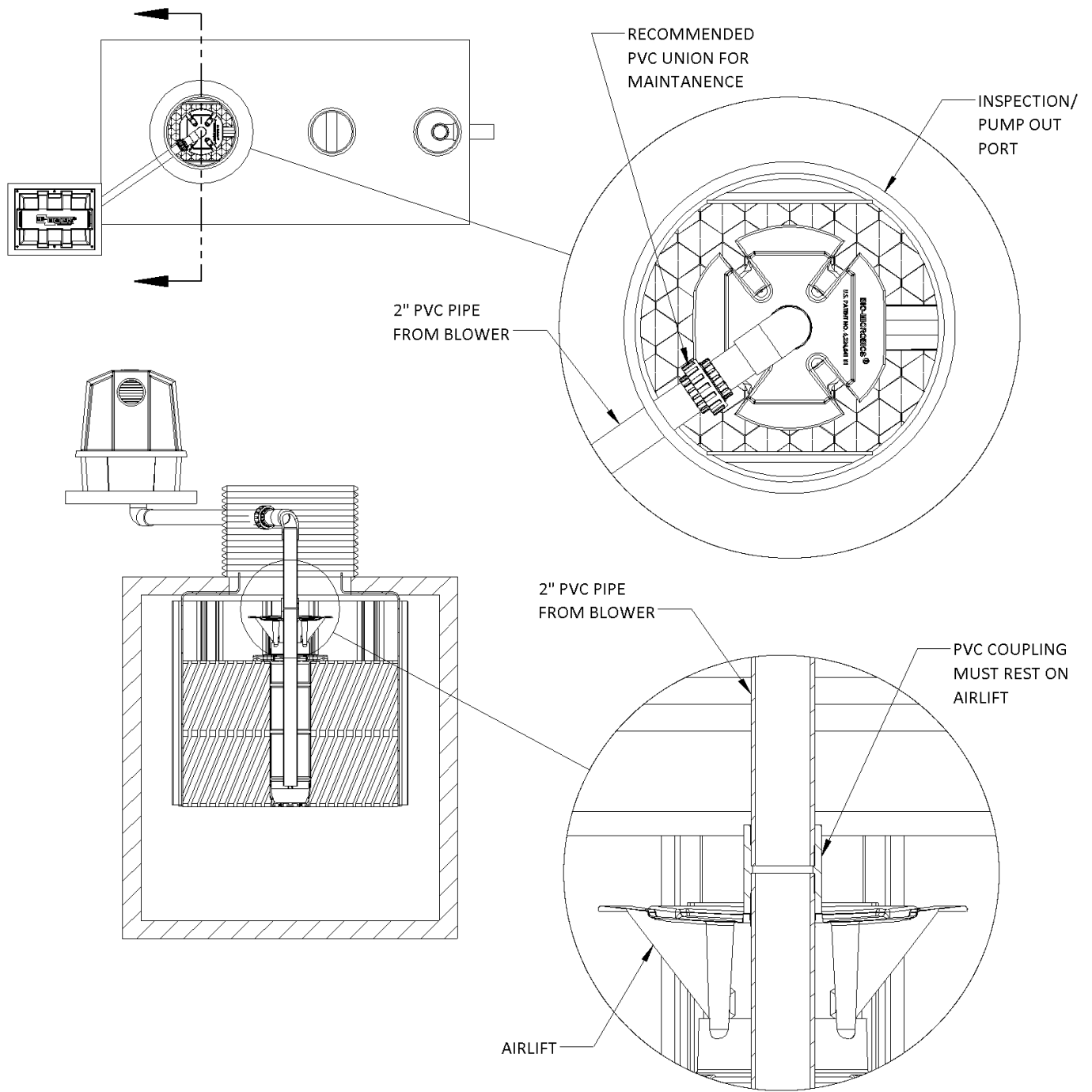

AIRLINE SIZING CHART

FAST® Model	PVC Pipe Size (OD)	Pipe Rating
Flex 0.4 & Flex 0.5	2" (2.38") / 51 mm (60.3 mm)	Schedule 40 or 80

VENTING

There are several options for proper venting. The most common are mentioned here. The vent system must be sized properly to avoid excessive back pressure in the system (see table below). It must not allow surface water to enter the system and must allow internal condensation to drain.

REMOTE VENT: Penetrate the riser for the vent pipe opening. Insert vent pipe into riser and seal the riser penetration to prevent infiltration. Run the vent pipe to the desired location and terminate above grade. Cover opening with #4 mesh screen or similar. Water accumulating in the vent piping must be drained to prevent back pressure. **NOTE:** The vent should not exceed 100 ft [30.5 m] in length.

BIOFILTER: Please contact BioMicrobics for guidance on how to build a buried vent using wood chips and pipe. (BioFilter not shown).

FAST® MODEL	MIN. VENT DIAMETER	VENT OPENING
MicroFAST® Flex 0.4 & Flex 0.5	3 in [7.6 cm]	7.0 in ² [45 cm ²]

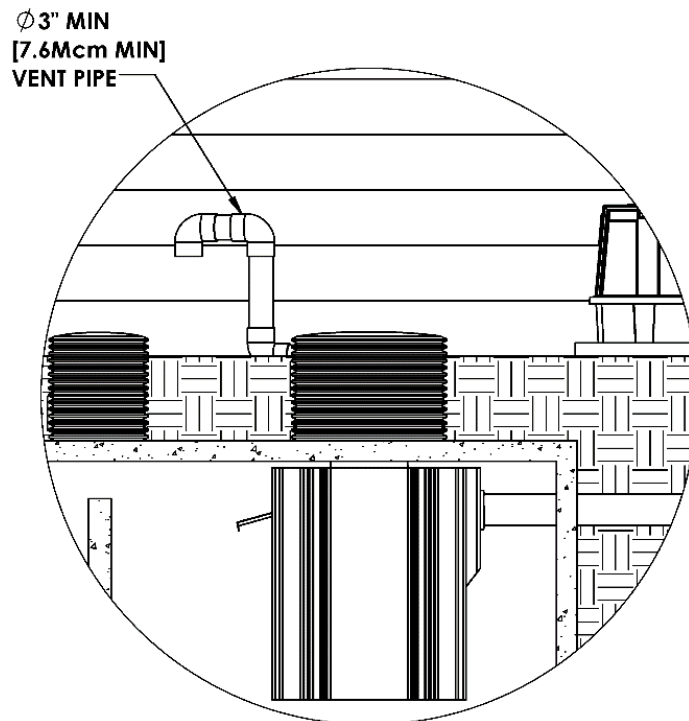

BLOWER INSTALLATION

CAUTION

ALWAYS HAVE ALL UTILITY LINES AND EQUIPMENT MARKED BY A LOCATING SERVICE PROVIDER PRIOR TO PERFORMING ANY WORK.

WARNING

ALL ELECTRICAL WORK MUST BE PROPERLY PERFORMED BY A QUALIFIED ELECTRICIAN PER ALL APPLICABLE CODES. FAILURE TO DO SO MAY RESULT IN SEVERE BODILY INJURY OR DEATH.

1. The blower and blower housing must be mounted on a pad to avoid settling. All conduit/piping should pass through the pad from below. Blower must be located above flood levels.
2. Secure lower blower housing to pad using 4 supplied #14 x 1½" self-tapping screws. Drill screws directly into blower pad.
3. Connect initial blower fittings (right).
4. Connect airline from FAST® unit to blower outlet using required piping (not included). We recommend a union be installed inside the housing on the blower outlet piping for easy removal of blower. Keep all debris out of airline. All connections must be air-/watertight.
5. Connect incoming power to the blower at the blower junction box. Be sure to follow the supplied wiring diagram for the voltage at your specific location. All blowers are dual voltage and must be connected according to the proper diagram. Blower diagrams can be found on the blower's shipping box and at the end of this manual.

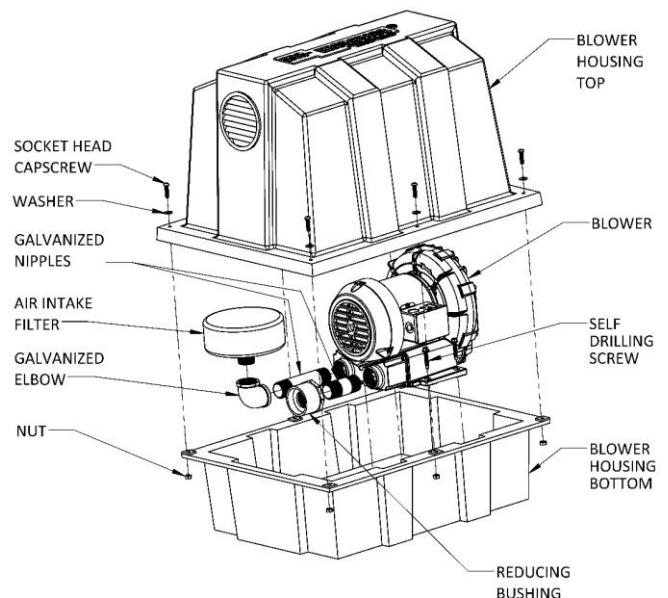
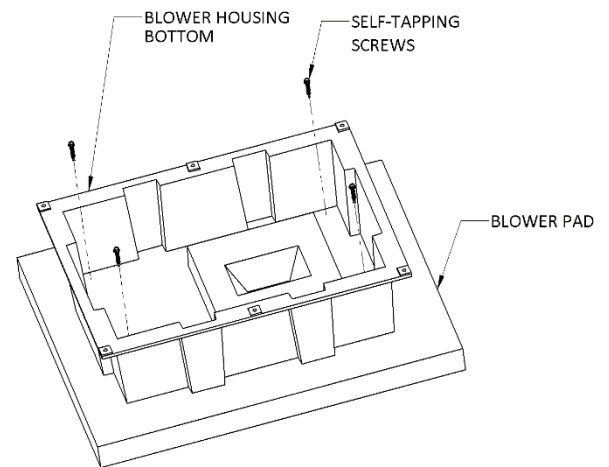

BLOWER WIRING DIAGRAMS

NOTE: This information is provided for convenience. Always check with the blower manufacturer literature and manuals for the most current wiring and installation information.

FUJI 110V

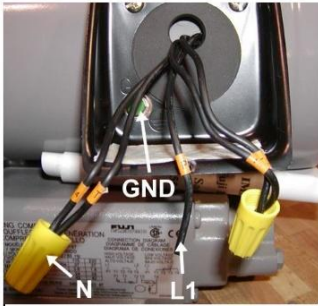

Model: FUJI VFC-200-5T, -300-5T
 Power: 110VAC
 - L1 to P1
 - N to T2, T4
 - T1 & T3, cap together

FUJI 220V



Model: FUJI VFC-200-5T, -300-5T
 Power: 220V 1ø
 - L1 to P1
 - L2 to T4
 - T2 & T3, cap together
 - T1, cap off

MAPRO 110V

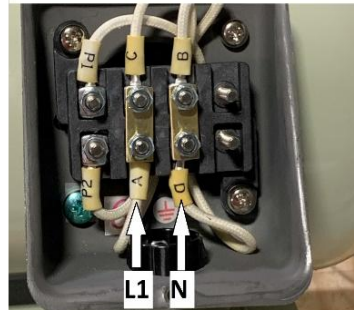

Brass Jumper 1 Connects A&C
 Brass Jumper 2 Connects D&B
 L1 Connects to A (or C)
 N Connects to D (or B)

MAPRO 220V

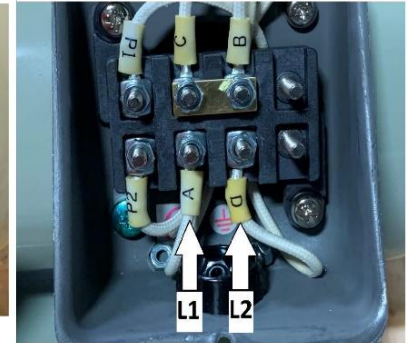

Brass Jumper Connects C & B
 L1 Connects to A
 L2 Connects to D

BLOWER WIRING DIAGRAMS

FUJI BLOWER 1 PHASE

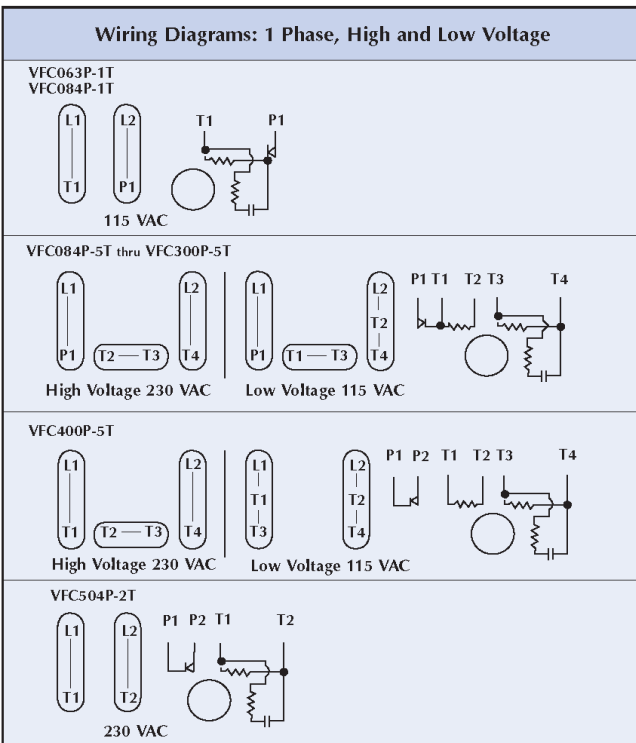

MAPRO BLOWER 1 PHASE

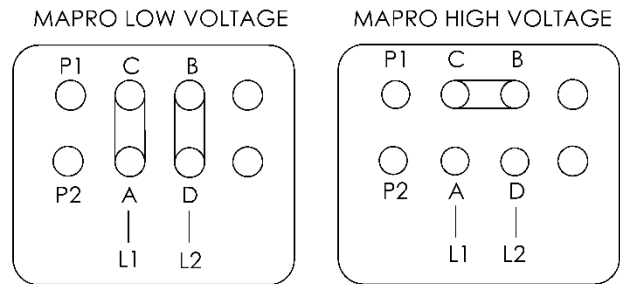

CONTROL PANEL INSTALLATION

⚠ CAUTION

ALWAYS HAVE ALL UTILITY LINES AND EQUIPMENT MARKED BY A LOCATING SERVICE PROVIDER PRIOR TO PERFORMING ANY WORK.

⚠ WARNING

ALL ELECTRICAL WORK MUST BE PROPERLY PERFORMED BY A QUALIFIED ELECTRICIAN PER ALL APPLICABLE CODES. FAILURE TO DO SO MAY RESULT IN SEVERE BODILY INJURY OR DEATH.

All FAST® system electrical parts are certified for safety. The control panel enclosures meet NEMA4X standards for all-weather use (but not explosive or submerged environments).

1. Examine wiring directions for the supplied FAST® control panel. Make sure the facility electrical supply matches the label on the control panel and is compatible with the blower (voltage, phase, frequency, amperage, etc.).
2. A dedicated breaker is required in the building's master electrical panel. Make connections between the master panel and FAST® control panel.
3. Make connections between blower and FAST® control panel per the electrical diagram.
4. BioMicrobics control panels can also be used with optional external inputs and outputs, such as dry contact input and output for alarm signaling.
5. BioMicrobics manufactures control panels that also power UV systems. The track system (or other auto-dialer) can also be connected to the panel.
6. For voltage, see label on control panel box.

CONTROL PANEL DETAILS

With every FAST® unit, BioMicrobics provides a control panel that will match the electrical supply selected and the power requirements of the blower. The table below summarizes the control panel details for the various configuration options.

Enclosure Type	Dimensions Height, Width, Depth	Voltage	Phase	Frequency Hz	Amperage
Hinged NEMA-4X	9 x 9¾ x 5 ¼ in [22.9 x 24.8 x 13.3 cm]	110VAC	1	60	10 A
Hinged NEMA-4X	9 x 9¾ x 5 ¼ in [22.9 x 24.8 x 13.3 cm]	220VAC	1	60	10 A

SMALL CONTROL PANEL

The smaller FAST® control panels are provided with hinged enclosures. The face of the panel enclosure features model and serial numbers, power indicator lamp, alarm indicator lamp, alarm silence button, and blower breaker switch. The electrical details of the control panel are printed on a label affixed to the outside of the enclosure. The inside of the control panel contains a printed circuit board. The small panels have terminations for incoming and outgoing power mounted directly on the circuit board. The circuit board also provides optional power to a UV-light system up to 2 amps. The UV terminals supply the same voltage that is wired to the board input terminals.

The circuit board has two sets of normally open dry contacts for optional connections such as a float switch or pressure switch. The normally open contacts will activate the panel alarm when closed. Next to these contacts are a 12VDC terminal which can be used to power an external dialer device, and an alarm output terminal which can be used to signal an external device when the panel goes into alarm. The alarm output is a normally open switch that will close during an alarm condition.

Current Sensors

The small FAST® control panel features two current sensors: (1) the “UV” current sensor, which can be activated to detect a failed UV bulb when the current drawn is less than 5 milliamps (activating the panel alarm), and (2) a blower current sensor, which measures the current used by the blower; it will signal an alarm if the blower draws less than 0.5 amps. A maximum threshold for blower current will signal an alarm and is adjustable up to 15 amps.

Activate Current Sensor

To activate either the UV current sensor or the blower current sensor, move the jumper on the labeled current sensor pins from the right-most two pins to the left-most two pins, as shown below.

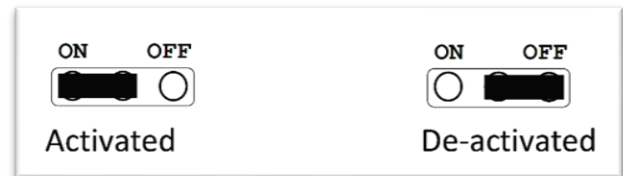

Adjust Current Sensor

To adjust the blower current sensor maximum threshold, turn the small screw on the front of the sensor clockwise to increase and counter-clockwise to decrease.

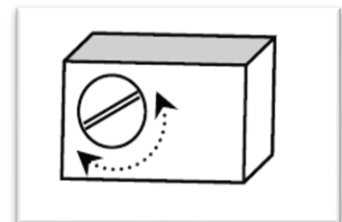

Note: *Adjust the blower current sensor at system startup with a full FAST® tank.*

In order to properly set the blower current sensor, the FAST® treatment tank must be filled with water to the normal operating level. With power supplied to the panel and the blower running, adjust the current sensor up or down until the point at which the alarms starts buzzing or stops buzzing. Once the spot is found, turn the current sensor screw $\frac{1}{4}$ to $\frac{1}{2}$ of a rotation clockwise to set the blower current maximum threshold.

SMALL CONTROL ENCLOSURE



SMALL CONTROL BOARD LAYOUT

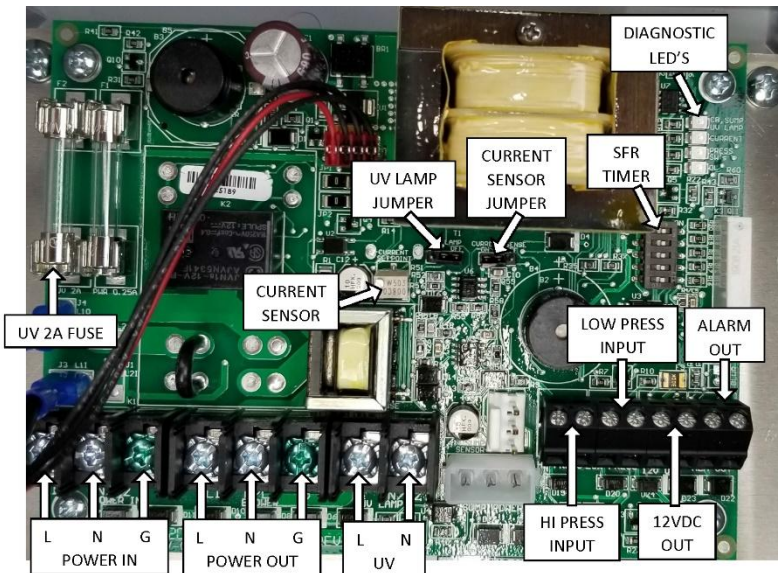

110V

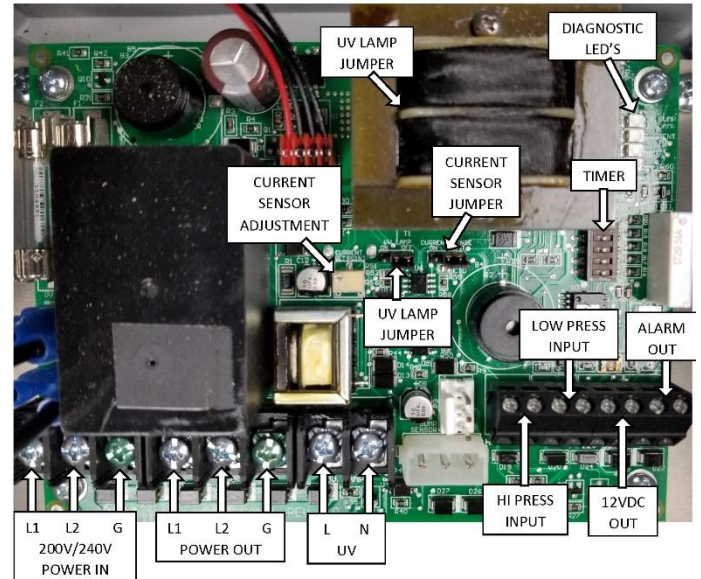

220V

110V SMALL CONTROL PANEL

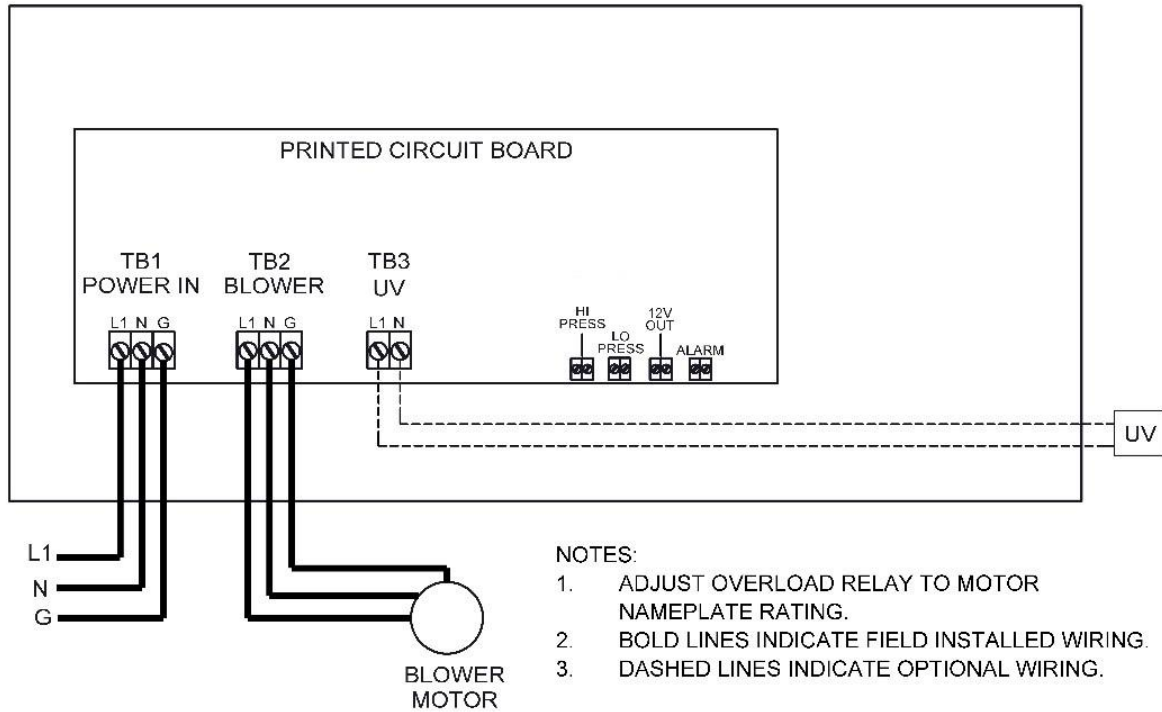

200-240V SMALL CONTROL PANEL

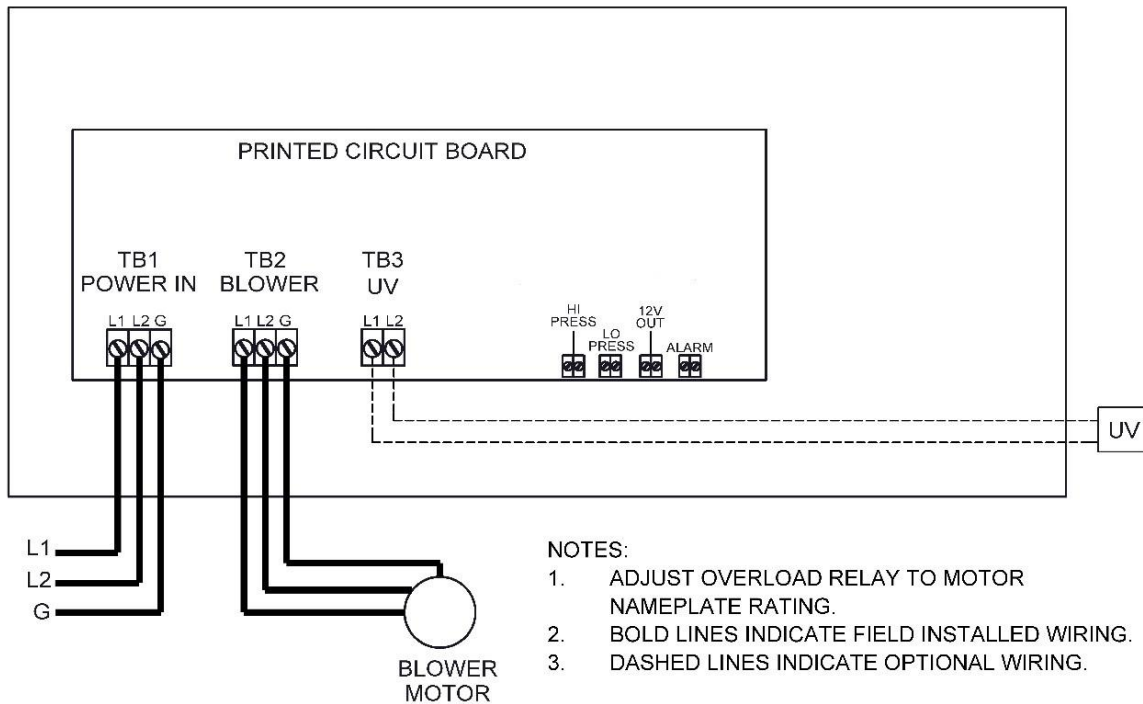

FINAL INSPECTION AND STARTUP

It is the installer's responsibility to ensure that the tank will not float due to hydraulic conditions at the site. Your local FAST® systems distributor may provide installation inspection services. If you have questions, call BioMicrobics at 800-753-FAST (3278) or (913) 422-0707.

BEFORE THE UNIT IS BACKFILLED:

1. Fill the tank to the normal operating level.
2. Check for leaks in all watertight seals.
3. Turn the blower on and observe the operation of the airlift. A robust splash should be present.
4. Check for excessive back pressure: Seal all access covers, place hand about 8 in [20 cm] from FAST® vent. If you feel air flow beyond what makes a piece of paper flutter (that is, the "paper test"), then there is excessive back pressure, and the system's vent must be upgraded.
5. Check for proper water level over the media. The normal water line should be ~2 in [5 cm] over the media.
6. Check for proper alarm function. Turn off the blower circuit breaker and wait for the alarm to sound. If the alarm does not sound after 30 seconds, review the electrical installation procedures.
7. Turn the blower back on.
8. Backfill the excavation.
9. Finally, record the FAST® unit's serial number and other requested information in this Installation Manual, in the Service Manual, and in the Owner's Manual.

LIMITED WARRANTY

BioMicrobics, Inc. warrants the following systems

RetroFAST® 0.15, 0.25, 0.375

Residential MicroFAST® Flex 0.4, Flex 0.5, 0.5, 0.625, 0.75, 0.9, and 1.5

BioBarrier 0.5, 1.0, 1.5, 0.5-N, 1.0-N, and 1.5-N

STAAR® 0.5, 0.75, 1.0, 1.2, and 1.5

against defects in materials and workmanship, for a period of two years after installation or 30 months from date of shipment. For all other systems and spare parts, BioMicrobics Inc. warrants against defects in materials and workmanship for a period of one year after installation, or eighteen months from date of shipment, whichever occurs first, subject to the following terms and conditions.

TERMS AND CONDITIONS

Note: For this warranty to be effective, BioMicrobics must have received the product registration for the system.

During the warranty period, if any part is defective or fails to perform as specified when operating at design conditions, and if the equipment has been installed and is being operated and maintained in accordance with the written instructions that BioMicrobics, Inc. has provided, BioMicrobics, Inc. will repair or replace at its discretion such defective parts free of charge. Defective parts must be returned by owner to BioMicrobics, Inc.'s factory postage paid, if so requested. The cost of labor and all other expenses resulting from replacement of the defective parts and from installation of parts furnished under this warranty shall be borne by the owner. This warranty does not cover general system misuse, aerator components that have been damaged by flooding or any components that have been disassembled by unauthorized persons, improperly installed or damaged due to altered or improper wiring or overload protection. This warranty applies only to the treatment system and does not include any of the structure wiring, plumbing, drainage, septic tank or disposal system. BioMicrobics, Inc. reserves the right to revise, change or modify the construction and/or design of the BioMicrobics system, or any component part or parts thereof, without incurring any obligation to make such changes or modifications in present equipment. BioMicrobics, Inc. is not responsible for consequential or incidental damages of any nature resulting from such things as, but not limited to, defect in design, material, or workmanship, or delays in delivery, replacements or repairs.

THIS WARRANTY IS IN LIEU OF ALL OTHER WARRANTIES EXPRESS OR IMPLIED. BIOMICROBICS, INC. SPECIFICALLY DISCLAIMS ANY IMPLIED WARRANTY OF MERCHANTABILITY OR FITNESS FOR A PARTICULAR PURPOSE. NO REPRESENTATIVE OR PERSON IS AUTHORIZED TO GIVE ANY OTHER WARRANTY OR TO ASSUME FOR BIOMICROBICS, INC. ANY OTHER LIABILITY IN CONNECTION WITH THE SALE OF ITS PRODUCTS.

KEEP FOR YOUR RECORDS

FAST® SYSTEM SERIAL NUMBER: _____

INSTALLATION DATE: _____

SYSTEM DESIGNER: _____

SYSTEM INSTALLER: _____

TANK MANUFACTURER: _____